



# APPLICATION SOLUTION P16 #01 A

## DIGITAL POTENTIOMETER MOTOR SPEED APPLICATION (WITH OUTPUT MONITORING)

A manufacturer wants to control a speed of his motor with a product that has up and down arrows and have a digital display of the output signal in feet per minute. His motor drive controller needs a 0-10 VDC signal. He is presently adjusting the voltage signal using a potentiometer with markings next to the pot's knob.

### PRODUCTS USED: P1641100

A product for this application is the P1641100. The P1641100 is a process input PID controller with analog output. However, the analog output can be configured to follow the operator's desired setpoint value.

### HOW IT WORKS

The analog output is assigned to setpoint value in module 2-OP. In this same module, the output type is assigned to 0-10 VDC or 4-20 mA with the scaling of the low and high values to the desired engineering units.

In module 1-IN, the top display is programmed. For this case, the output of the P16 is looped back into the input of the same P16. In this case, the low and high display values would be the same values as used in module 2-OP analog out. The input type to the P16 must be programmed the same as the output type of the P16. For voltage P16 output, the output is wired in parallel back to the P16 input. For current P16 output, the output is wired in series through the P16 input. For current, terminal 10 is now the negative output. The "With Top Display Showing P16 Output Signal" illustration should be used.

### DESIGN ADVANTAGES

The operator no longer has to turn a knob to a marking. He can enter values in his specific engineering units to a resolution up to 0.00. He can visually monitor the P16 output or feedback from an external signal.

### ADDITIONAL CAPABILITIES

There are two alarms in this model, which could be used to detect high or low levels of speed when using the external signal in the top display. Setpoint limits could be programmed to limit operators from entering an unacceptable value. A fixed second setpoint value could be programmed that would be used with the F1 button or the user input. The output could be based on PID control when feedback signal is used. The P16 family of products could be programmed with a PC by using Red Lion cable TP16KIT1 and Crimson software. The P48 product line could be used in place the P16 product line.

## DIP SWITCH OR JUMPER SETTINGS

Make sure the internal analog output jumpers are in the correct location for the needed output type.

## PROGRAMMING (ONLY NON-FACTORY SETTINGS SHOWN)

**1-In** (Top Display: scaling the same  
as output 2-OP ANLO and ANHI)

tyPE : Curr or Volt (same as 2-OP ANtP)

dSP1 : 0 or Engineering Unit (Low)

INP1 : 4 or 0

dSP2 : Engineering Unit (High)

INP2 : 20 or 10

**2-OP** (Output program)

CYct : 0 (Turns off O1 annunciator.)

ANtP : 4-20 or 0-10

ANAS : SP (assign analog out to follow setpoint)

ANLO : 0 or Engineering Unit (Low)

ANHI : Engineering Unit (High)

**3-LC**

OP : LOC

PId : LOC

AL : LOC

SPrP : LOC

tUNE : LOC

**4-AL**

ACT1 : NONE

Act2 : NONE

## WIRING DIAGRAM P16 #01 A

All wiring must be according to the installation guidelines listed in the product's specifications.

### With Top Display Showing P16 Output Signal

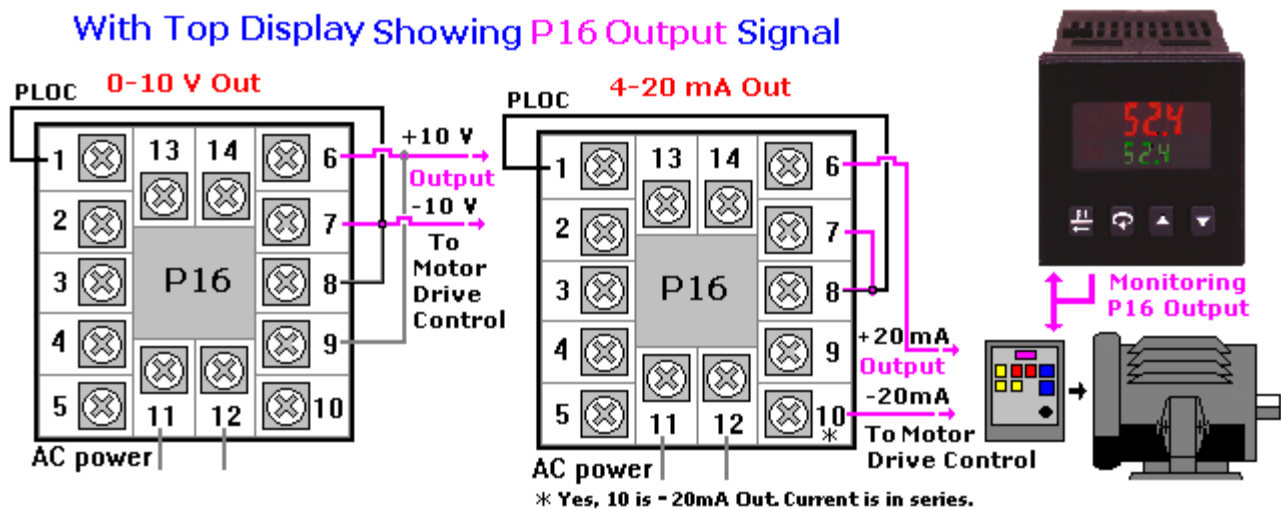

This application note is intended to be an example. Your specific application may require changes in products, programming and/or wiring. For specific assistance, you may contact your local Red Lion products supplier or Red Lion Controls Technical Support at 717-767-6511.



# APPLICATION SOLUTION P16 #01 B

## DIGITAL POTENTIOMETER MOTOR SPEED APPLICATION (WITH INPUT MONITORING)

A manufacturer wants to control a speed of his motor with a product that has up and down arrows and have a digital display from an external monitoring signal in feet per minute. His motor drive controller needs a 0-10 VDC signal. He is presently adjusting the voltage signal using a potentiometer with markings next to the pot's knob.

## PRODUCTS USED P1641100

A product for this application is the P1641100. The P1641100 is a process input PID controller with analog output. However, the analog output can be configured to follow the operator's desired setpoint value.

## HOW IT WORKS

The analog output is assigned to setpoint value in module 2-OP. In this same module, the output type is assigned to 0-10VDC or 4-20mA with the scaling of the low and high values to the desired engineering units.

In module 1-IN, the top display is programmed. For this case, the output of the P16 is not looped back into the input of the same P16. The "With Top Display Showing External Input Signal" illustration should be used.

To monitor the external signal from the motor, the low and high input display values and input type would correspond to the feedback device signal. (The input type to the P16 does not have to be the same as the output type of the P16.) The feedback device signal in this application is only used to monitor the process.

## DESIGN ADVANTAGES

The operator no longer has to turn a knob to a marking. He can enter values in his specific engineering units to a resolution up to 0.00. He can visually monitor the P16 output or feedback from an external signal.

## ADDITIONAL CAPABILITIES

There are two alarms in this model, which could be used to detect high or low levels of speed when using the external signal in the top display. Setpoint limits could be programmed to limit operators from entering an unacceptable value. A fixed second setpoint value could be programmed that would be used with the F1 button or the user input. The output could be based on PID control when feedback signal is used. The P16 family of products could be programmed with a PC by using Red Lion cable TP16KIT1 and Crimson software. The P48 product line could be used in place the P16 product line.

## DIP SWITCH OR JUMPER SETTINGS

Make sure the internal analog output jumpers are in the correct location for the needed output type.

## PROGRAMMING (ONLY NON-FACTORY SETTINGS SHOWN)

**1-In** (Top Display: scaling for the external input)

tyPE : Curr or Volt

dSP1 : 0 or Engineering Unit (Low)

INP1 : 4 or 0

dSP2 : Engineering Unit (High)

INP2 : 20 or 10

**2-OP** (Output program)

CYct : 0 (Turns off O1 annunciator.)

ANtP : 4-20 or 0-10

ANAS : SP (assign analog out to follow setpoint)

ANLO : 0 or Engineering Unit (Low)

ANHI : Engineering Unit (High)

**3-LC**

OP : LOC

PId : LOC

AL : LOC

SPrP : LOC

tUNE : LOC

**4-AL**

Act1 : NONE

Act2 : NONE

## WIRING DIAGRAM P16 #01 B

All wiring must be according to the installation guidelines listed in the product's specifications.

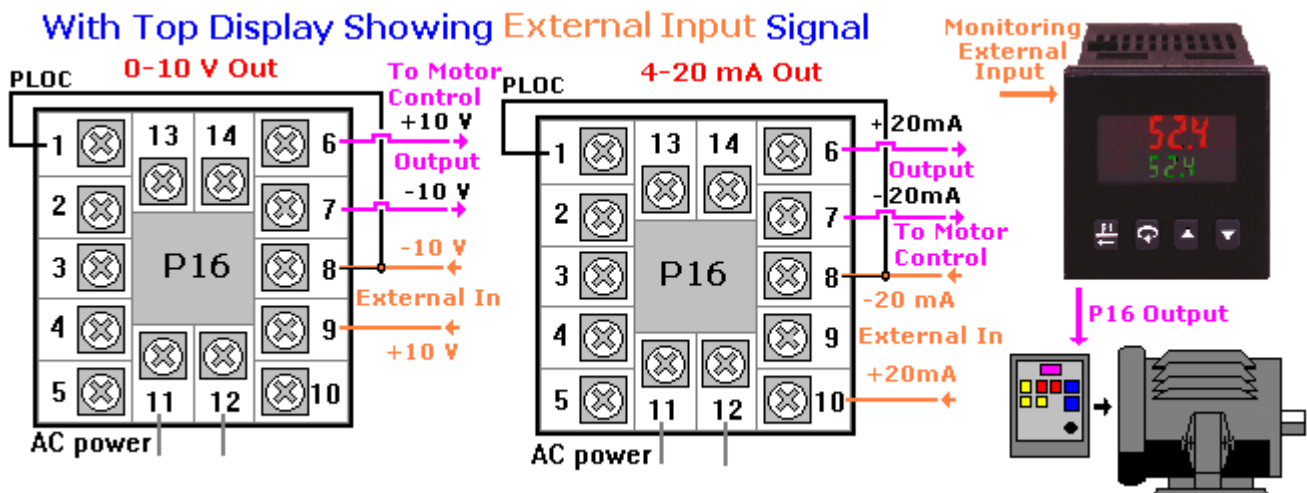

This application note is intended to be an example. Your specific application may require changes in products, programming and/or wiring. For specific assistance, you may contact your local Red Lion products supplier or Red Lion Controls Technical Support at 717-767-6511.